

# CLAMPBOE<sup>®</sup>

## CONTRACTOR<sup>®</sup>



### ROTARY HAMMER DRILL

MODEL NO: CRD1100

PART NO: 6479610

### OPERATION & MAINTENANCE INSTRUCTIONS



ORIGINAL INSTRUCTION

GC0920 - REV 1

---

## INTRODUCTION

---

Thank you for purchasing this CLARKE Hammer Drill. The CRD1100 is designed for general drilling/masonry drilling/chiselling/drill & hammer use in light industrial applications.

Before attempting to use this product, please read this manual thoroughly and follow the instructions carefully. In doing so you will ensure the safety of yourself and that of others around you, and you can look forward to your purchase giving you long and satisfactory service.

---

## GUARANTEE

---

This product is guaranteed against faulty manufacture for a period of 12 months from the date of purchase. Please keep your receipt which will be required as proof of purchase.

This guarantee is invalid if the product is found to have been abused or tampered with in any way, or not used for the purpose for which it was intended.

Faulty goods should be returned to their place of purchase, no product can be returned to us without prior permission.

This guarantee does not effect your statutory rights.

---

## INVENTORY

---

1	1100 Watt Rotary Hammer Drill with Front Handle Assembly	7	13 mm Keyed Chuck with SDS+ Chuck Adaptor
2	250 mm Bull Point Chisel	8	Dust Shield Cup
3	20 mm Flat Chisel	9	Chuck Key
4	8 mm TCT Drill Bit	10	Pot of Grease
5	10 mm TCT Drill Bit	11	Depth Stop Rod
6	12 mm TCT Drill Bit		

---

# SAFETY PRECAUTIONS

---



**WARNING: READ ALL INSTRUCTIONS. FAILURE TO FOLLOW ALL INSTRUCTIONS LISTED BELOW MAY RESULT IN ELECTRIC SHOCK, FIRE AND/OR SERIOUS INJURY. THE TERM "POWER TOOL" IN ALL WARNINGS LISTED BELOW REFERS TO YOUR HAMMER DRILL.**

---

## WORK AREA

1. **Keep work area clean and well lit.** *Cluttered and dark areas invite accidents.*
2. **Do not operate power tools in explosive atmospheres, such as in the presence of flammable liquids, gases or dust.** *Power tools create sparks which may ignite the dust or fumes.*
3. **Keep children and bystanders away while operating a power tool.** *Distractions can cause you to lose control.*

## ELECTRICAL SAFETY

1. **Avoid body contact with earthed or grounded surfaces such as pipes, radiators, ranges or refrigerators.** *There is an increased risk of electric shock if your body is earthed or grounded.*
2. **Do not expose power tools to rain or wet conditions.** *Water entering a power tool will increase the risk of electric shock.*
3. **When operating a power tool outdoors, use an extension cord suitable for outdoor use.** *Use of a cord suitable for outdoor use reduces the risk of electric shock.*

## PERSONAL SAFETY

1. **Stay alert, watch what you are doing and use common sense when operating a power tool. Do not use a power tool while you are tired or under the influence of drugs, alcohol or medication.** *A moment of inattention while operating power tools may result in personal injury.*
2. **Use safety equipment. Always wear eye protection.** *Safety equipment such as dust mask, non-skid safety shoes, or hearing protection used for appropriate conditions will reduce personal injuries.*
3. **Avoid accidental starting. Ensure the switch is in the off position before connecting to the power supply.**
4. **Do not overreach. Keep proper footing and balance at all times.** *This enables better control of the power tool in unexpected situations.*

5. **Dress properly. Do not wear loose clothing or jewellery. Keep your hair, clothing and gloves away from moving parts.** *Loose clothes, jewellery or long hair can be caught in moving parts.*







## **POWER TOOL USE AND CARE**

1. **Do not force the power tool. Use the correct power tool for your application.** *The correct power tool will do the job better and safer at the rate which it was designed.*
2. **Do not use the power tool if the switch does not turn it on and off.** *Any power tool that cannot be controlled with the switch is dangerous and must be repaired.*
3. **Disconnect the battery before making any adjustments, changing accessories, or storing power tools.** *Such preventive safety measures reduce the risk of starting the power tool accidentally.*
4. **Store idle tools out of the reach of children and do not allow persons unfamiliar with the power tool or these instructions to operate the power tool.** *Power tools are dangerous in the hands of untrained users.*
5. **Maintain power tools. Check for misalignment or binding of moving parts, breakage of parts and any other condition that may affect the power tools operation. If damaged, have the power tool repaired before use.** *Many accidents are caused by poorly maintained power tools.*
6. **Keep cutting tools sharp and clean.** *Poorly maintained cutting tools with sharp cutting edges are less likely to bind and are easier to control.*
7. **Use the power tool and accessories in accordance with these instructions and in the manner intended for the particular type of power tool, taking into account the working conditions and the work to be performed.** *Use of the power tool for operations different from intended could result in a hazardous situation.*

## **SERVICE**

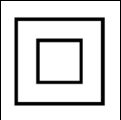
1. **Have your power tool serviced by a qualified repair person using only identical replacement parts.** *This will ensure that the safety of the power tool is maintained.*

## SAFETY SYMBOLS

	Read instruction manual before use		Wear dust mask
	Class 2 Double Insulated		Wear ear defenders
	CE Mark		Wear safety glasses
	Weeee Directive		

## ENVIRONMENTAL RECYCLING POLICY



By purchasing this product, the customer is taking on the obligation to deal with its safe disposal in accordance with the Waste Electrical and Electronic Equipment (WEEE).

 This product must not be disposed of with general household waste but be disposed of according to the laws governing Waste Electrical and Electronic Equipment (WEEE) at a recognised disposal facility.

This product contains valuable raw materials. Metal products should be taken to your local civic amenity site for recycling.

## ELECTRICAL CONNECTIONS



**WARNING: READ THESE ELECTRICAL SAFETY INSTRUCTIONS THOROUGHLY BEFORE CONNECTING THE PRODUCT TO THE MAINS SUPPLY.**

Before switching the product on, make sure that the voltage of your electricity supply is the same as that indicated on the rating plate. Connecting it to any other power source may cause damage.

If it is necessary to change the fuse in the plug, the fuse cover must be refitted. If the fuse cover becomes lost or damaged, the plug must not be used until a suitable replacement is obtained.

If the plug has to be changed due to damage, a replacement should be fitted, following the wiring instructions shown below. The old plug must be disposed of as insertion into a mains socket could cause an electrical hazard.



**WARNING: THE WIRES IN THE POWER CABLE OF THIS PRODUCT ARE COLOURED IN ACCORDANCE WITH THE FOLLOWING CODE:  
BLUE = NEUTRAL    BROWN = LIVE**

If the colours of the wires in the power cable of this product do not correspond with the markings on the terminals of your plug, proceed as follows.

- The **Blue** wire must be connected to the terminal which is marked **N** or coloured **Black**.
- The **Brown** wire must be connected to the terminal which is marked **L** or coloured **Red**.

**Plug must be BS1363/A approved.**

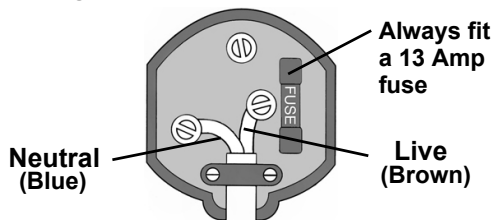

**Ensure that the outer sheath of the cable is firmly held by the clamp**

**We strongly recommend that this machine is**

**connected to the mains supply via a Residual Current Device (RCD)**

If in any doubt, consult a qualified electrician. DO NOT attempt any repairs yourself.



**This symbol indicates that this is a Class II product, and does not require an earth connection.**

# OVERVIEW

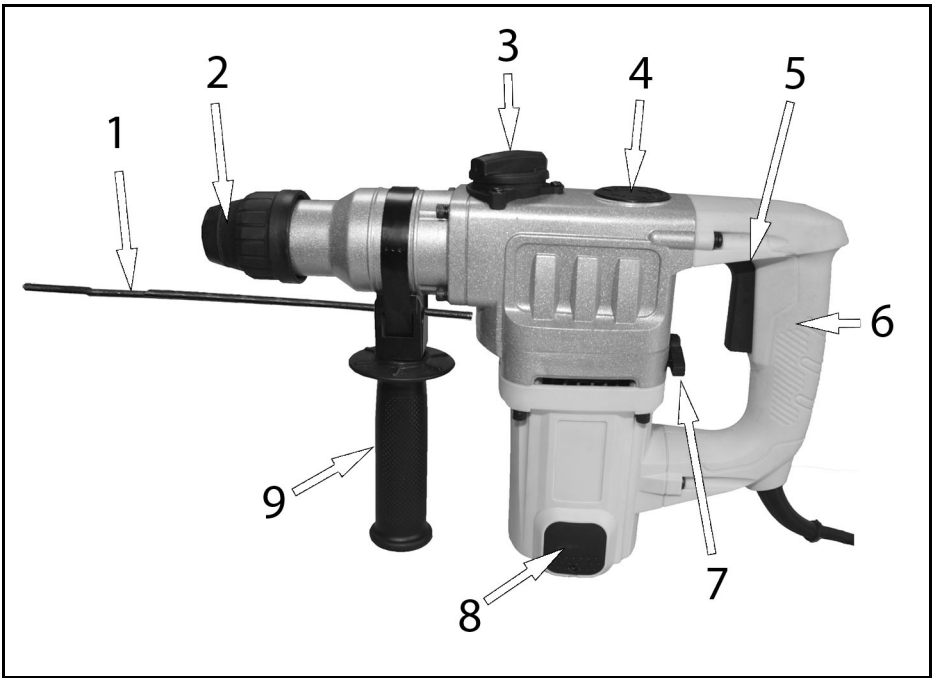

NO	DESCRIPTION	NO	DESCRIPTION
1	Depth Stop	6	Rear Handle
2	SDS Chuck	7	Hammer On/Off Control
3	Rotation On/Off Selector Switch	8	Motor Brush Access Panel
4	Grease Port Cover	9	Front Handle
5	Trigger		

---

## BEFORE USE

---

### INSERTING A DRILL BIT / CHISEL

The chuck clamps SDS drill bits and chisels without the need for a chuck key.

1. Pull back the collar.
2. Insert the bit.
3. Turn the bit in the chuck until it latches.
4. Release the collar to lock in place.
5. Check by pulling the bit to see if it is locked in place.

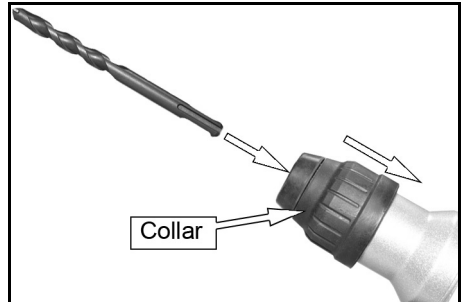

**IMPORTANT:** Always clean the shaft of the drill bit before inserting into the chuck.

**IMPORTANT:** Do not allow dust or debris to get inside the chuck as this will cause problems in the future.

### REMOVING A BIT

1. Slide the collar to the rear and pull the bit out of the chuck.



CAUTION: WHEN REMOVING A BIT FROM THE DRILL, REMEMBER THAT IT MAY BE EXTREMELY HOT. EITHER ALLOW IT TO COOL DOWN FIRST OR USE INDUSTRIAL GLOVES TO REMOVE THE BIT.

### USING THE DRILL CHUCK ADAPTOR

When drilling with non SDS drill bits, a 13mm chuck (supplied) can be inserted into the SDS chuck as shown.

Use the supplied chuck key to open/close the chuck jaws.

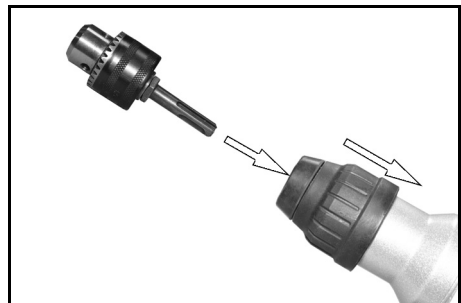



## POSITIONING THE FRONT HANDLE

The front handle can be positioned left, right or centre as required.

1. Loosen the front handle by twisting it clockwise (when viewed from above).
2. Rotate the front handle to the required position.
3. Secure the front handle by twisting it anticlockwise (when viewed from above).

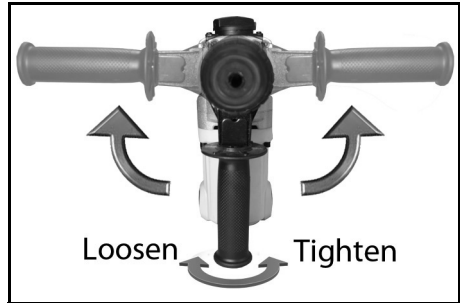

## USING/SETTING THE DEPTH STOP

The depth stop can be fitted to the front handle as shown.

1. To install the depth stop, loosen the support handle by turning it anticlockwise.
2. Insert the depth stop rod through the hole in the front handle and set to the required depth, adjusting the position of the handle attachment if required.
3. Secure in place by re-tightening the front handle.



## SELECTING THE OPERATING MODE

Mode	Hammer Action selector	Rotation selector
Drill Only	Drill Only	ON
Hammer Drill	Hammer Assisted Drilling	ON
Hammer only (no rotation)	Hammer Assisted Drilling	OFF

### HAMMER ACTION SELECTOR

1. With the drill not operating, set the hammer action selector to the required setting.
  - Left - Hammer Assisted Drilling
  - Right - Drill Only

**IMPORTANT:** When using the “hammer action” you only need to apply light pressure. Too much pressure will place unnecessary load on the motor. Check the drill bits regularly, re-sharpen or replace if required.



### ROTATION ON/OFF SELECTOR

Some jobs require the chuck to remain stationary yet still have the hammer effect, such as chiselling concrete, plaster etc.

- Set the rotation selector to the right for “Rotation OFF”.
- Set the rotation selector to the left for “Rotation ON”.

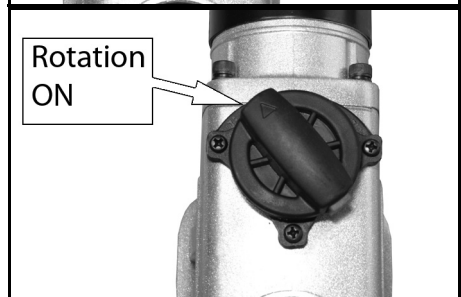
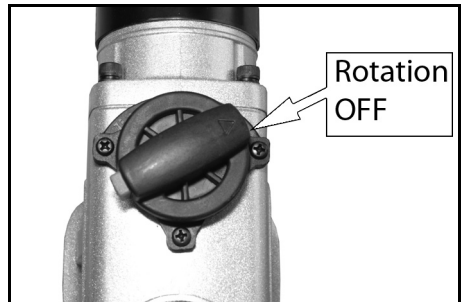

---

## USING THE DRILL

---

### BEFORE STARTING WORK

1. Before drilling into walls and floors etc., check first that there are no hidden electrical cables, gas or water pipes etc.
2. Check the mains voltage before plugging in and switching on.
3. Ensure the work area is as hazard free as possible.

### STARTING WORK

1. Select and install the bit to be used. See page 8.
2. If required, set the depth stop and adjust the support handle attachment for the most comfortable position. See page 9.
  - For safety, always use the hammer drill with the front handle attached.
3. Set the required operating mode. See page 10.
4. When drilling vertically overhead, fit the rubber dust cap shown onto the drill bit.

5. Position the tool against the surface to be drilled and pull the trigger switch.
  - If using the hammer action do not start the drill until the tool is in contact with the work surface.

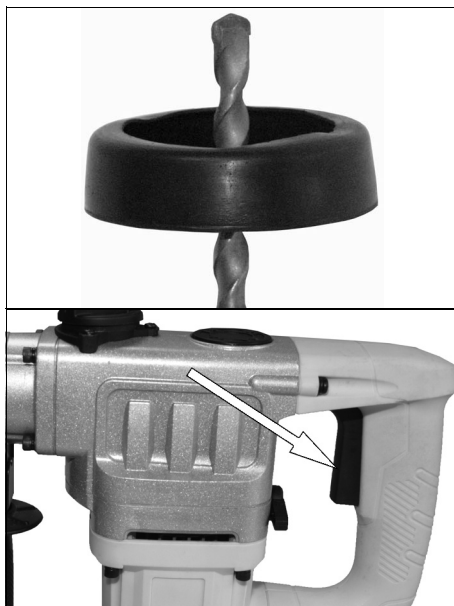

### STOPPING WORK

- Release the trigger and wait until the bit has stopped before placing the drill on any surface.

## DRILLING TIPS

- Always use sharp, good quality drill bits. The performance of your drill is dependant on the quality of the bits used.
- After drilling material to the full depth, do not simply pull out the drill but maintain chuck rotation to ease withdrawal.
- Reduce the pressure on the drill bit when it is about to break through. This will prevent the drill from jamming.
- If drilling a large hole, first drill a pilot hole using a smaller drill bit.
- Always apply pressure to your drill bit in a straight line and, where possible, at right angles to the workpiece.
- When drilling in metal, the materials being drilled can become hot. To reduce overheating use a suitable cooling lubricant. No cooling lubricant is necessary when drilling cast iron or brass as they should be drilled dry.
- When drilling metal, the harder the metal the slower the drill speed. Similarly, the bigger the drill bit the slower the speed.
- To prevent the drill bit from slipping when starting to drill a hole in metal, use a centre punch to make an indentation at the start point.
- Always start drilling at a slow speed to prevent the drill from slipping out of the pop mark or indent, gradually increasing speed until the optimum cutting speed is achieved whilst maintaining a MODERATE pressure ONLY. NEVER force the drill bit into the work. This will overheat the tip and cause it to dull very quickly.
- When drilling in wood, clamp a piece of scrap wood to the underside of the material to avoid splintering.
- Large holes should be drilled with wood augers, flat wood bits or hole saws.

## CHANGING THE MOTOR BRUSHES

1. Remove the screw indicated and lift off the motor brush access panel.

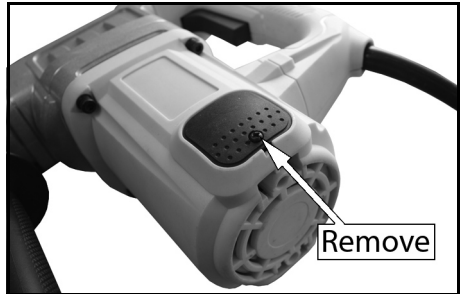

2. Use a flat screwdriver to undo the cap.

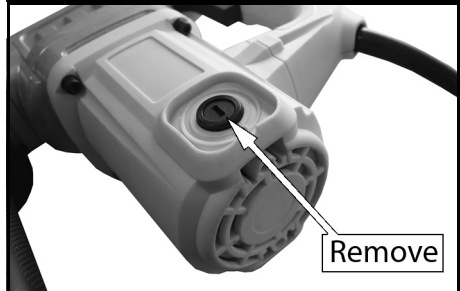

3. Lift off the cap.

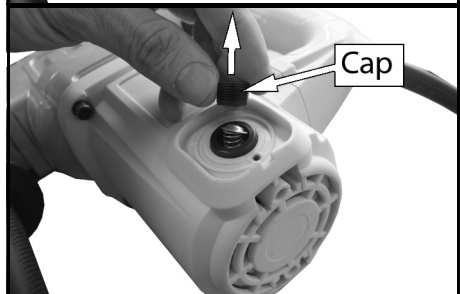

4. Lift out the brush and replace with a new one.
5. Repeat steps 1-4 on the other side of the motor.

**NOTE:** Both brushes must be replaced at the same time.

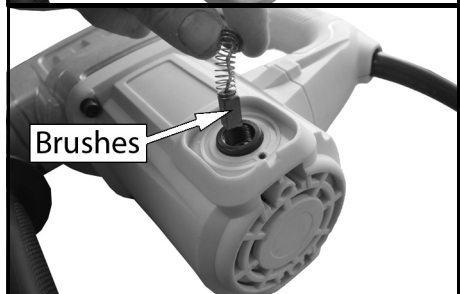

---

## MAINTENANCE AND SERVICING

---

1. After use, remove the drill bit and tap the side of the chuck to remove any dust or chippings etc.
2. Keep the handle clean and free from oil and grease.
3. Worn or damaged parts must be replaced by qualified personnel.
4. Clean the drill regularly, use a soft brush and or soft cleaning cloth. DO NOT use any chemicals or harsh abrasives to clean the drill.
5. At the end of work, to prevent dust deposits use compressed air (max.3 bar) to clean out the ventilation holes.
6. Remove and inspect the carbon brushes occasionally, it is very important to refit the motor brushes exactly as they are removed, DO NOT turn them around or swap their positions (dirty or worn carbon brushes result in excessive sparking and speed faults).
7. Always replace the motor brushes in pairs.

### GEARBOX GREASE

Check gearbox occasionally and top up if necessary with a good quality high melting point grease.

1. Remove the grease port cover.
2. Apply sufficient grease to cover all visible moving parts.
  - DO NOT overfill the gearbox.
3. Replace the cover before using the drill again.



---

## SPECIFICATIONS

---

Chuck capacity/type	SDS plus 13mm keyed chuck adapter
Rotational Speed	950 rpm
Impact Rating (blows/min)	4200
Maximum Drilling Capacity:	Wood - 40 mm Steel - 13 mm Concrete - 28 mm
Sound Pressure Level	88.8dB LpA
Sound Power Level	99.8 dB LWA
Vibration Level	Rotary hammer 17.914m/s <sup>2</sup> Chiselling hammer 16.832 m/s <sup>2</sup>
Weight	4.95 kg (drill only)
Dimensions (LxHxW)	376 x 256 x 98
Duty Cycle classification	S1 Continuous

# PARTS DIAGRAM

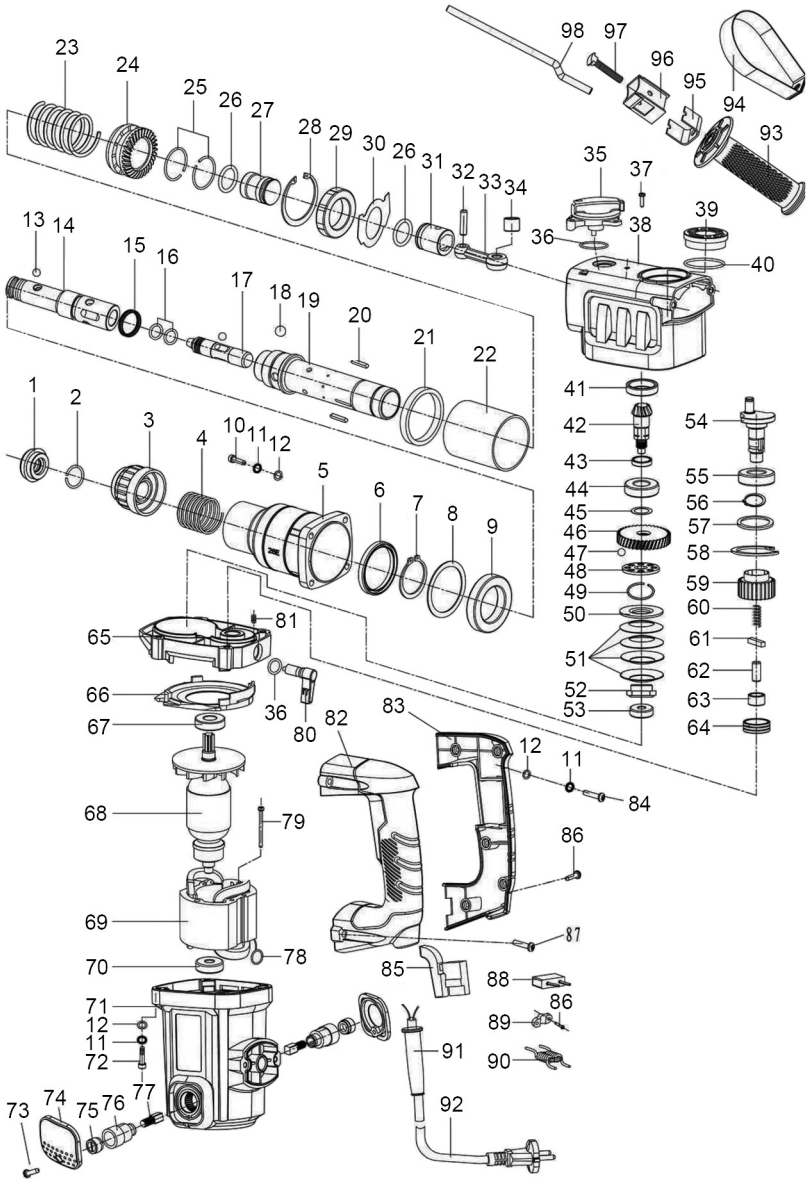



## PARTS LIST

ID	DESCRIPTION	ID	DESCRIPTION
1	Rubber Cap	31	Piston
2	Circlip	32	Piston Pin
3	Collar	33	Connecting Rod
4	Spring	34	Steel Cover
5	Chuck Housing	35	Switch Assembly
6	Oil Seal	36	O-ring
7	Circlip	37	Hex Bolt
8	Washer	38	Gearbox Casing
9	Bearing	39	Grease Port Cover
10	Screw	40	O-ring
11	Spring Washer	41	Oil Seal
12	Flat Washer	42	Bevel Gear
13	Steel Ball	43	Adjusting Washer
14	Teleflex	44	Bearing
15	Oil Seal	45	Adjusting Washer
16	O-ring	46	Gear
17	Punch Hammer	47	Steel Ball
18	Steel Ball	48	Fixed Plate
19	Cylinder	49	Check Ring
20	Flat Key	50	Active Plate
21	Plastic Ring	51	Butterfly Spring
22	Plastic Cylinder Case	52	Retaining Nut
23	Spring	53	Bearing
24	Gear	54	Crankshaft
25	Ring	55	Bearing
26	O-ring	56	Circlip
27	Hammer	57	Washer
28	Circlip	58	Circlip
29	Bearing	59	Gear
30	Oil Plate	60	Spring

<b>ID</b>	<b>DESCRIPTION</b>
61	Key
62	Dome Pin
63	Bearing
64	Steel Cover
65	Middle Cover
66	Fan Cover
67	Bearing
68	Rotor
69	Stator
70	Bearing
71	Main Housing
72	Screw
73	Screw
74	Brush Holder Cover
75	Brush Holder Cap
76	Brush Holder
77	Brush
78	Spring
79	Screw

<b>ID</b>	<b>DESCRIPTION</b>
80	Switch Assembly
81	Screw
82	Handle Left Side
83	Handle Right Side
84	Screw
85	Trigger
86	Screw
87	Screw
88	Capacitor
89	Cable Clamp
90	Inductor
91	Cable Sleeve
92	Plug And Power Cable
93	Handle Grip
94	Hoop
95	U-bracket
96	Bracket
97	T-screw
98	Depth Stop Rod

When ordering spare parts, please quote the reference TMCCRD110001 onwards. e.g. Switch Assembly will be TMCCRD110080.

# DECLARATION OF CONFORMITY



**Clarke**<sup>®</sup>  
**INTERNATIONAL**

Hemnall Street, Epping, Essex CM16 4LG

## DECLARATION OF CONFORMITY

This is an important document and should be retained.

We hereby declare that this product(s) complies with the following directive(s):

- 2014/30/EU      *Electromagnetic Compatibility Directive.*  
2006/42/EC      *Machinery Directive.*  
2011/65/EU      *Restriction of Hazardous Substances, (amended by 2015/863).*

The following standards have been applied to the product(s):

- EN 60745-1:2009 +A11:2010, EN 60745-2-6:2010, EN 55014-1:2017, EN 55014-2:2015,  
EN 61000-3-2:2014, EN 61000-3-3:2013.*

The technical documentation required to demonstrate that the product(s) meet(s) the requirement(s) of the aforementioned directive(s) has been compiled and is available for inspection by the relevant enforcement authorities.

The CE mark was first applied in: 2014

**Product Description:** Rotary Hammer Drill  
**Model number(s):** CRD1100  
**Serial / batch Number:** N/A  
**Date of Issue:** 10/09/2020

Signed:

J.A. Clarke  
Director

# A SELECTION FROM THE VAST RANGE OF

# Clarke®

## QUALITY PRODUCTS

### AIR COMPRESSORS

From DIY to industrial, Plus air tools, spray guns and accessories.

### GENERATORS

Prime duty or emergency standby for business, home and leisure.

### POWER WASHERS

Hot and cold, electric and engine driven - we have what you need

### WELDERS

Mig, Arc, Tig and Spot. From DIY to auto/industrial.

### METALWORKING

Drills, grinders and saws for DIY and professional use.

### WOODWORKING

Saws, sanders, lathes, mortisers and dust extraction.

### HYDRAULICS

Cranes, body repair kits, transmission jacks for all types of workshop use.

### WATER PUMPS

Submersible, electric and engine driven for DIY, agriculture and industry.

### POWER TOOLS

Angle grinders, cordless drill sets, saws and sanders.

### STARTERS/CHARGERS

All sizes for car and commercial use.



## PARTS & SERVICE: 0208 988 7400

**Parts Enquiries**  
[Parts@clarkeinternational.com](mailto:Parts@clarkeinternational.com)

**Servicing & Technical Enquiries**  
[Service@clarkeinternational.com](mailto:Service@clarkeinternational.com)

SALES: UK 01992 565333 or Export 00 44 (0)1992 565335

**Clarke** INTERNATIONAL Hemnall Street, Epping, Essex CM16 4LG  
[www.clarkeinternational.com](http://www.clarkeinternational.com)